



T-349-A



T-352-A



T-350-01-A

TEJEX
TEJEX
TEJEX
TEJEX
TEJEX
TEJEX
TEJEX
TEJEX
TEJEX
TEJEX
TEJEX

Inset BRACKETS
the adjustable solution



Inset Bracket, Universal*

B-394 Polybag

2 T-349-A Universal Inset Brackets
4 HAR-079 #7 x 2" Washerhead Combo FT Type 17 Screw
2 HAR-080 #8 - 32 x 1/2" Machine Screw FHP
Sold 50 Polybags per Box

T-349-A

Bulk Box

Sold 200 parts per Box

For Bulk Orders, parts HAR-079 & HAR-080 will need to be purchased

Additional Hardware for Bulk Box Orders

B-391: HAR-079 (400)

B-392: HAR-080 (200)

**Works with BLUM, GRASS, KV, ACCURIDE, SALICE, FUTABA (additional slides may work, but please test your slide before purchases)*



Inset Bracket, Universal* FOR BEADED FRAMES

B-427 Polybag

2 T-352-A Universal Inset Brackets
4 HAR-079 #7 x 2" Washerhead Combo FT Type 17 Screw
2 HAR-080 #8 - 32 x 1/2" Machine Screw FHP
4 HAR-083 #6 - 18 x 3/4" Trusshead Type 17 Screw
Sold 50 Polybags per Box

**Replaces BLUM #
295.7130**

T-352-A

Bulk Box

Sold 200 parts per Box

For Bulk Orders, parts HAR-079, HAR-080 & HAR-083 will need to be purchased

Additional Hardware for Bulk Box Orders

B-391: HAR-079 (400)

B-392: HAR-080 (200)

B-388 HAR-083 (400)

**Works with BLUM, GRASS, KV, ACCURIDE, SALICE, FUTABA (additional slides may work, but please test your slide before purchases)*



Inset Bracket, Handed*

B-393 Polybag

1 T-350-A and 1 T-350-01-A Universal Inset Brackets
4 HAR-079 #7 x 2" Washerhead Combo FT Type 17 Screw
2 HAR-080 #8 - 32 x 1/2" Machine Screw FHP
Sold 50 Polybags per Box

T-350-A (L) / T-350-01-A (R)

Bulk Box

Sold 100 parts per Box (100 Left or 100 Right)

For Bulk Orders, parts HAR-079 & HAR-080 will need to be purchased









Additional Hardware for Bulk Box Orders

B-391: HAR-079 (400)

B-392: HAR-080 (200)

**Works with BLUM, GRASS, KV, ACCURIDE, SALICE, FUTABA (additional slides may work, but please test your slide before purchases)*

The Inset Bracket Advantage

-  Self Locating for Easy Mounting
-  Works with Flush Bottom Cabinets (Universal Only)
-  Smooth Horizontal Adjustment
-  Anti-Slip Die Cast Insert
-  Made with Strong Glass Filled Polycarbonate
-  Attractive Wood Tone Coloring
-  Replaces Cumbersome Wood Blocks
-  Works with a Variety of Undermount Slides

Rear Brackets for Inset Undermount Applications

Tenn-Tex Plastics has designed specialty Undermount Rear Brackets for Inset Applications. When you install the Front Inset Brackets, the Undermount Drawer Slide must be mounted further back in the cabinet. The standard Overlay Rear Brackets will not allow the drawer slide to move further into the cabinet. The Inset Back Brackets from Tenn-Tex will allow you to mount your slide within 13 mm of the back panel. The Brackets have over 17 mm of side to side adjustment. Our Inset Rear Brackets will work with most undermount drawer slides. They are available with dowels for multiple drill patterns or in a screw on version. You can find our Inset Bracket Item Numbers in our Bracket Solutions Catalog at www.bracketsolutions.com.

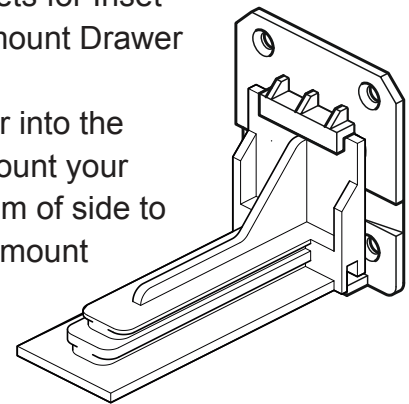

Common Item Numbers for Rear Brackets for Inset Applications. For additional parts, contact Tenn-Tex Plastics.

Item #	Attachment	Back	Drill Pattern	QTY
C-280	Screw-On		X = 1.5 / Y = 6.5	400 qty
C-308	8mm Dowel	1/8" Thick	X = 16 / Y = 3.5	400 qty
C-283 / C-283-01	10mm Dowels	1/4" Thick	X = 3.5 / Y = 8	400 qty
C-301 / C-301-01	10mm Dowels	1/8" Thick	X = 3.5 / Y = 8	400 qty
C-338 / C-338-01	10mm Dowels	1/4" Thick	X = 3.5 / Y = 3	400 qty
C-422 / C-422-01	10mm Dowels	1/8" Thick	X = 3.5 / Y = 3	400 qty

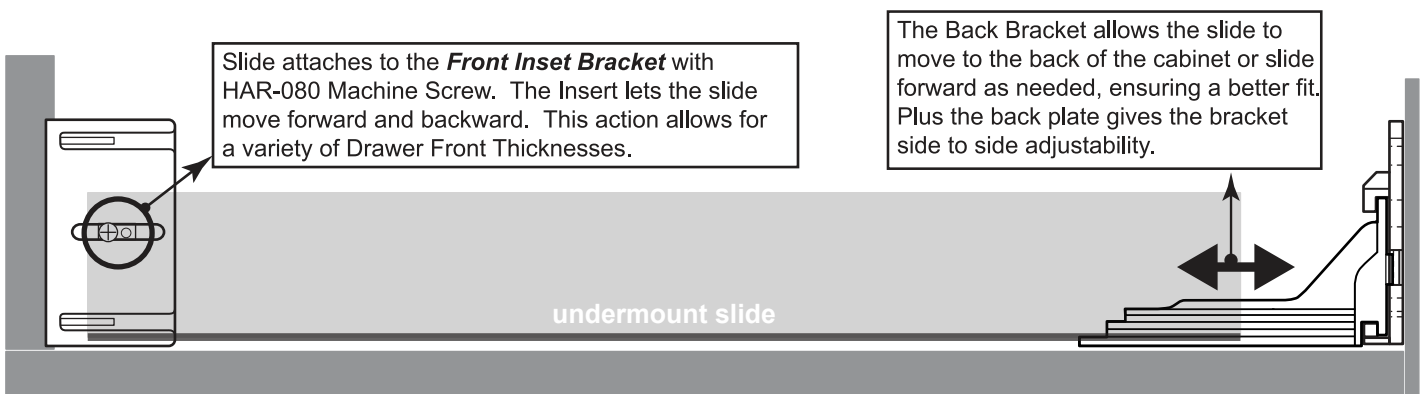

The TENN-TEX Plastics Advantage

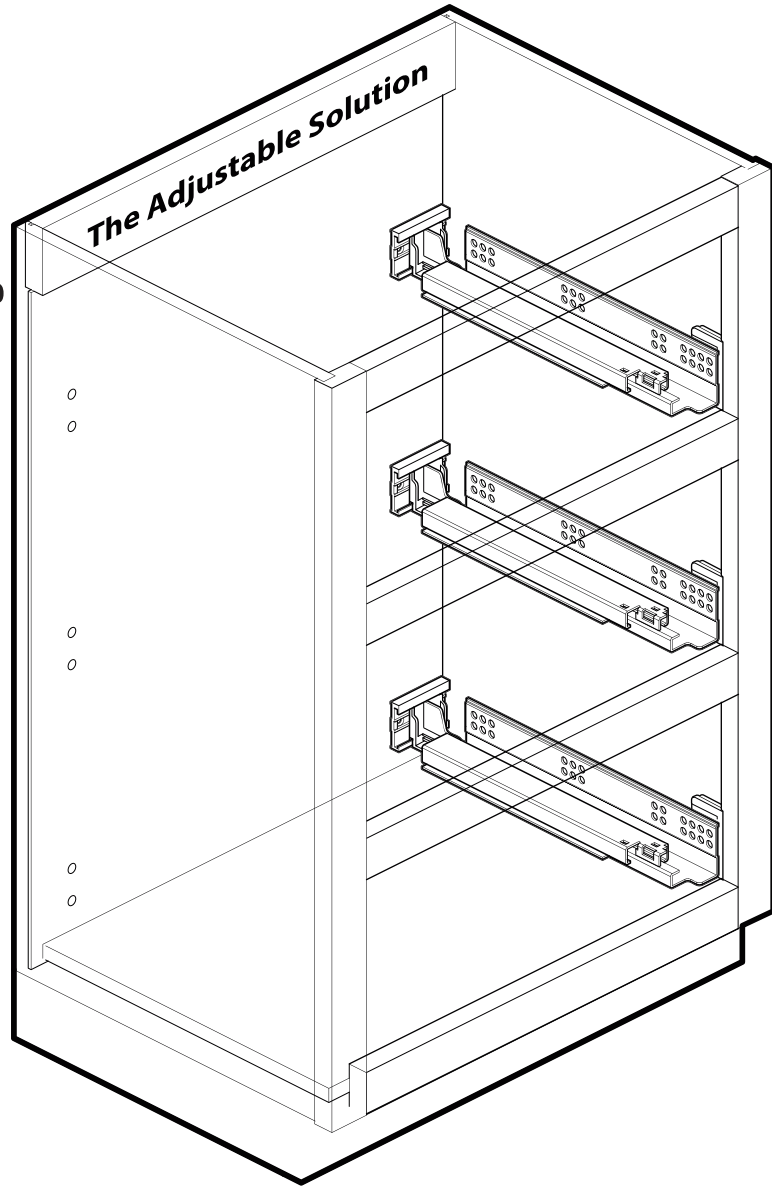

Inset BRACKETS the adjustable solution



1.800.TENN.TEX • 8011 National Service Road
Colfax, NC 27235 • WWW.TENNTEX.COM



August 2014



Made in the USA